

# Damage Controlled Structures for Extreme Loading

Akira WADA  
Professor and Head at  
Structural Engineering  
Research Center,  
Tokyo Institute of  
Technology,  
Yokohama 226-8503,  
Japan  
*wada@serc.titech.ac.jp*



Akira Wada, born 1946, received his Master degree at 1970 and his Doctor at 1981 from Tokyo Institute of Technology. He was a structural engineer at Nikken Sekkei Ltd. until 1981. He returned to Tokyo Institute of Technology at 1982 as an associate professor and promoted to a professor at 1989. He is a chairman of the structural engineering committee at Architectural Institute of Japan, now.

## Summary

The human life is about 80 years and the average life of buildings is 60-100 years. The interval when the severe earthquake happens at a place is very long as 100-2000 years. General people tend to think that it doesn't encounter the big earthquake if they are lucky. We consider the wind load and the snow load for designing the building structures. General people think that strong wind and heavy snow will come in the building life.

The earthquake load is a typical extreme event. In 1995, very big earthquake hit Kobe city, many buildings had severe damage to column and beams. Some of them were perfectly collapsed. After the earthquake, many buildings more than 80% of newly constructed high-rise buildings in Japan were designed using damage controlled design method.

The concept of damage controlled design method and some of buildings designed by the method will be introduced.

**Keywords:** high-rise buildings; strong earthquakes; redundancy; dampers; ductility; linear elastic analysis; allowable stress design; nonlinear analysis; ultimate strength design.

## 1. Introduction

The basis of modern theory of structures starts from Galilei Galileo. Strength of materials, strength of structures and equilibrium of structures were discussed about 400 years ago. Since then, the structural design is performed by repeating the following four processes. 1: Setting the design load conditions. 2: Designing the preliminary structures or improving the structures. 3: Calculating the response of the structures. 4: Confirming the response by the design criteria.

The setting the design load conditions is very important for the structural design process. The maximum earthquake or typhoon in an area occurs rare than once hundreds years. It is difficult that people or engineers experience these extreme events. Since our knowledge of structural engineering is not perfect, real load in some case would be out of our thought.

The proposed structure in the design process is analyzed under design load conditions and the response can be obtained. The linear elastic analysis is used for the allowable stress design procedure. The nonlinear elastic-plastic analysis is used for the ultimate strength design procedure.

Design criteria are changed according to the incidence of the load. It is preferable to set the multi levels of load condition, to examine the responses and to confirm the responses to the multi design criteria. In general, these levels are set by two stages or three stages.

When the load is thought to be an obvious event, the stress level of the structural material must be suppressed and the limit of the deformation and the vibration should be small. When the load is happen extremely rare, the plastic deformation of material is allowed and the limit of the

deformation or the vibration becomes large, too.

The damage-controlled design of building structures is discussed here for extreme strong earthquakes.

## 2. Overview of Seismic Design Trends in Japan

Japanese seismic design standards define two levels (level 1 and 2) of earthquake ground motions and allowable damage for each of these levels. For level 1, small and moderate earthquake ground motions, only minor damage such as cracks in walls and beams are allowed, while human life and the building functions and structure are protected. For level 2, a severe rare earthquake ground motions, a building structure may be damaged provided that human life is protected. The current seismic design and research in Japan are based on these requirements. However, since the buildings have recently increased in their sizes, and also because of the need to accommodate expensive computer and communication equipment, as well as the functionality of such equipment, the above conventional design requirements need to be modified. The lessons learned from the Northridge and Hyogoken-Nanbu earthquakes emphasize the need to recognize that the damage to the structural and non-structural- systems designed according to the previous philosophy may result in great human life and economic losses. It is obvious that too large plastic deformation in structural and non-structural- systems of a building should not be allowed for severe earthquake ground motions. Furthermore, construction activities requiring the production of cement and steel raise new concerns about environmental problems, such as ruining rain forests and increasing CO<sub>2</sub>. The severity of these problems could be reduced by lengthening the building's service life. Thus, it became clear that a new design approach was needed such that buildings, especially large important buildings, remain functional not only after moderate earthquake ground motions but even after a severe event. A promising approach appears to be in the use of the concept of "damage-tolerant" structural system, which is described next.

The concept of a "damage-tolerant" structure was proposed in Japan before the Northridge and the Kobe earthquakes [1]. Damage tolerant means that the acceptable damage due to an earthquake occurs in specific structural components (such as braces, shear walls or supplemental energy dissipating devices) that are added to what is called "primary structural system." These damaged components are called the "sacrificing members" and function somewhat like a fuse to protect the primary structure from severe damage. After the 1994 Northridge and 1995 Hyogoken-Nanbu earthquakes, "damage-tolerant" or damage-controlled structures have received increasing attention by researchers and structural engineers especially in the United States and Japan. Therefore, it is not surprising that the investigation of the seismic behaviour of damage controlled structures and its applications in the design and construction of buildings located in regions of high seismicity have widely increased worldwide [2], [3], [4], [5], [6], [7] and [8].

On the cover of the Engineering News-Record [9], the word "sacrificial" was used together with a conceptual picture of a damage controlled structures and a short article. The article explains that the energy absorption that occurred from the axial yielding of the damping braces (they call sacrificial braces) that were used in the steel structural system will become the "sacrificed" braces through which high-rise building structure will survive even a severe earthquake ground motion. As is discussed later in this chapter, in special moment-resisting frames the welded flange of the beam-ends becomes sacrificed. Figure 1 shows a sketch of a typical beam-column connection in the United States before the Northridge earthquake. Little energy dissipation can be expected from the plastic deformation of these types of beam ends during a severe earthquake ground motion [10] (as was clearly demonstrated during the Northridge [11], [12], [13] and the Hyogoken-Nanbu earthquakes [14]) because the plastic deformation of the beam ends is equivalent to the method of mounting elasto-plastic energy dissipating devices in series with an elastic frame (Figure 2), leading to large deformation of the whole frame after it becomes plastic mechanism, which demands significant energy dissipation that the welded connections of the flanges cannot supply.

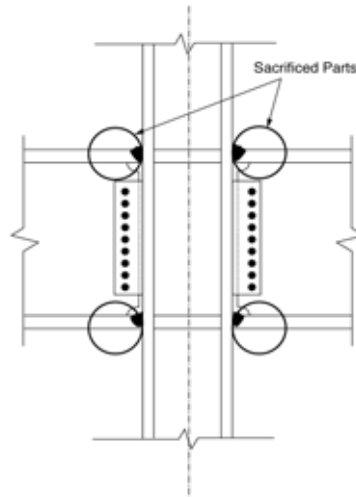

Fig. 1 Typical beam-column connection in the United States before Northridge earthquake.

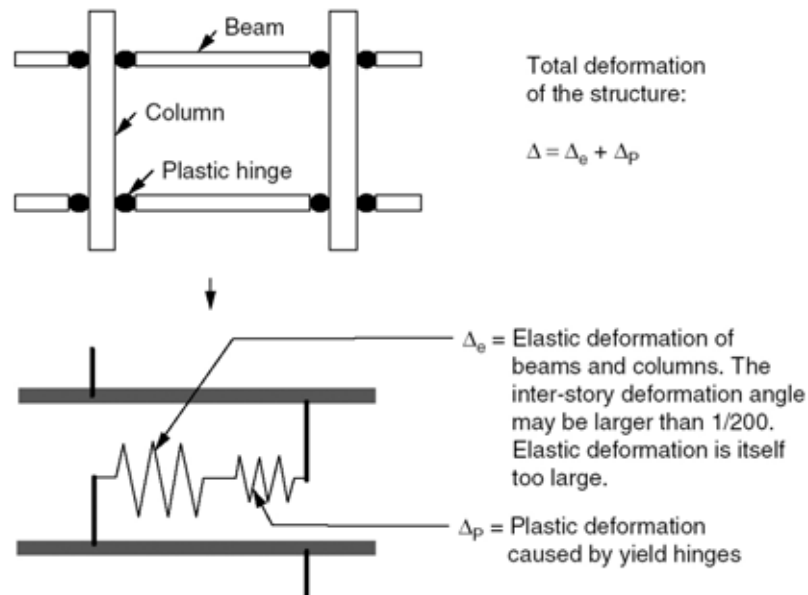

Fig. 2 Strong column weak beam model.

### 3. Seismic Design Criteria for Moment Resisting Frames in Japan

Japanese seismic design methods for building structures are different depending on whether the building height is beyond or under 60 m.

Time history response analysis is required for the seismic design of tall buildings more than 60 m high. For the small and moderate earthquake ground motions, the maximum velocity of ground motion is considered as 25 cm/sec or the associated maximum acceleration is approximately 250 cm/sec<sup>2</sup>. The interstory drift angle must be controlled to values under 0.5%. For a severe earthquake ground motion, the maximum velocity of ground motion is considered as 50 cm/sec or associated maximum acceleration is 500 cm/sec<sup>2</sup>; the interstory drift angle is required to be less than 1.0%.

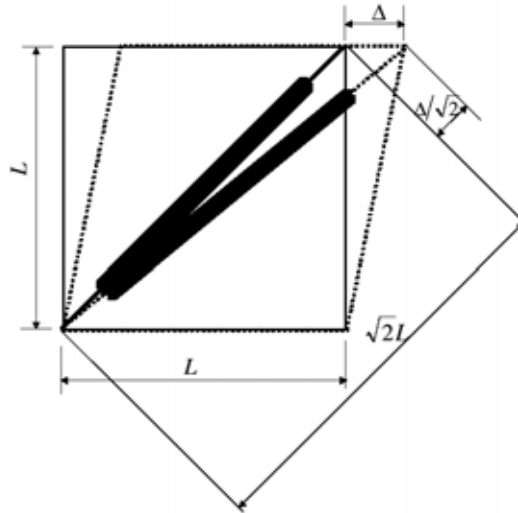

Fig. 3 Axial deformations of brace and shear deformation of frame.

#### 4. Deformation of Buildings

For a building to be functional, it must have not only structural components (beams, columns and walls), but also partitions, windows, doors, utility lines and equipment. The latter components are called non-structural members. These non-structural components are easily severely damaged when the interstory deformation of the building is very large [15].

Let us consider the lateral deformation of a frame consisting of a beam and column with a brace placed at  $45^\circ$ , as shown in Figure 3. Compared to the lateral shear deformation  $\pm\Delta$  occurring in the frame, the expansion and contraction of the brace becomes  $\Delta/\sqrt{2}$ . Because the brace length is  $\sqrt{2}$  times the column length  $L$ , the axial strain in the brace becomes 1/2 of the shear deformation angle of the frame. Taking into account the fact that the joints at the brace ends are of high stiffness and that they will remain elastic and assuming that the yield strain of the steel brace is 0.1%, it is found that when the brace yields, the story deformation angle is as small as 1/500.

For a steel plate shear wall, according to Von Mises's plastic theory, the yield shear stress of steel is  $1/\sqrt{3}$  times the yield normal stress. The shear elastic modulus is 1/2.6 times Young's modulus. The shear yield strain is then about 1.5 ( $=2.6/1.732$ ) times the axial yield strain. It means that the story deformation angle becomes about 1/667 when the steel plate shear wall begins to yield and it becomes plastic at almost the same level as the small story deformation angle for the brace. It is possible to make the story deformation angle at the beginning of plastic deformation smaller for the brace and steel plate wall by using ultra-low yield steel whose yield strength is between 100 and 200MPa.

Let us consider the yield deformation angle of a rigid joint frame comprising columns and beams, which receive an asymmetric bending moment (Figure 4). The total lateral deformation of a frame structure results from the effects of the following five components: bending deformation and shear deformation of columns, bending deformation and shear deformation of beams, and shear deformation of the panel zone in beam-column joint. In a regular building frame structure, the column section is usually larger than the beam section, and the column height is usually shorter than the beam span. Therefore, the column deformation is much smaller than the beam deformation. The beam bending deformation contributes approximately 50% of the total deformation of the whole frame structure. For the steel structure frame, discussion is focused on the rotational distortion occurring at the beam-ends. Let the span and the depth of the beam is  $L$  and  $D$ , respectively. Then, the deformation angle  $\theta_y$  at beam-ends, when the stress of the flange reaches the yield point  $\sigma_y$  becomes  $(\sigma_y/3E)(L/D)$  (see Figure 4).

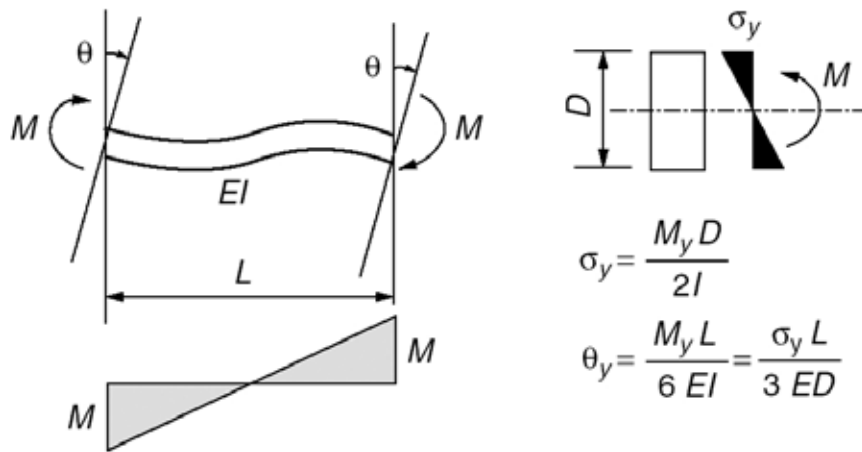

Fig. 4 Deformation angle at beam ends of a rigid frame.

The span  $L$  of the frame is predetermined and Young's modulus  $E$  is a constant of pre-selected material. Therefore, the deformation at the yield point of the frame can be increased by using steel having a high yield point  $\sigma_y$  and members having a smaller depth  $D$  than conventional ones. In other words, the elastic deformation capacity of a frame can be increased using a slender flexible frame manufactured by high strength steels. As a result, the yield deformation of the moment-resistant frame can be easily determined by selecting the materials and the depth of the structural members. On the contrary, the yield deformation of the controlling members such as braces or shear walls is determined from the overall configuration of the frame and the yielding strength of the selected material. Thus, the amount of plastic deformation cannot be increased by only adjusting the plate thickness and detailed configuration.

When the plastic deformation of the controlling or energy dissipating members are used in combination with the moment-resisting frame, neglecting problems such as brace buckling, shear failure of shear wall, etc., the following difficulties still occurred. Plastic deformations occur first in each of the controlling members (or regions of these members) rather than in the moment resisting frames, so stiffness and strength deterioration of the controlling members (braces or walls) occurs, while the strength of the frames continues to increase. Therefore, it is difficult to have a reliable estimation of the total response and strength of the structural systems.

The technology of damage-controlled structures is theoretically founded on motion-based design and is consistent with the concept of performance-based design [16], [17], [18]. This technology is not limited in the design of building structures, even in the design of industrial facilities at present, there is a trend to find better design variables to meet various design requirements. In many cases, the design requirements have to be changed during the long service period of the structure. The most important strategy of designing a structure is to simplify as much as possible the design requirements and design variables. The design strategy of damage controlled structures is based on a simple concept. The function of the building structure has two clear design requirements. One is to resist vertical gravity load, another is to resist the effects of earthquake ground motions. In the design process, the whole building structure can be divided into two individual design variables (structural systems). One is the primary structure such as beams and columns, which are designed to resist only the vertical service load; the other is the controlling or energy dissipating system, which is designed to resist the lateral forces resulting from the effects of earthquake ground motions.

## 5. Concept of Damage Controlled Structures

As pointed out previously, the basic concept of damage-controlled structures [1], [7] can be described as follows. The integrated entire building structural system is the combination of two different structures, as shown in Figure 5. One is the primary structure composed of beams and columns, which aims to resist the vertical service load. The primary structure is designed to behave elastically and to retain its building service functions even during a severe earthquake ground motion. The second is the energy dissipating or damage-controlling system that aims to control the effects of the lateral forces and deformations resulting from the earthquake ground motion. Thus, the damage induced by the earthquake ground motion is controlled by this energy dissipation system, which is easily checked and repaired or replaced after a severe earthquake ground motion.

Figure 6 illustrates the structural modelling of damage-controlled structures. The damage is controlled within the brace type energy dissipation system. The primary structural frame and the damage controlling system can be considered a system of two springs connected in parallel. The total deformation of the entire structure  $\Delta$  is equal to the frame deformation  $\Delta_f$  and also equal to the deformation  $\Delta_d$  of the energy dissipating system. The advantage of this structural system is to have a more reliable energy dissipation system with an increased energy dissipation capacity, stiffness and strength of the primary structure without increasing the total deformation of the entire structure.

Figure 7 compares the conventional strong column weak beam structures and the damage controlled structures with an energy dissipation system. For small and moderate earthquake ground motions, the conventional structures are designed to remain elastic. This means that the natural structural damping is the only mechanism that dissipates part of the input energy of these small and moderate earthquake ground motions. Thus, if the natural structural damping is overestimated during the design stage, the primary structure will be subjected to large deformation and force or yield even under small and moderate earthquake ground motions. However, in the case of a damage controlled structures the presence of the stiff energy dissipation component will initially restrict the deformations of the primary structure and then as the stiff component will yield under small lateral deformations, it will dissipate a part of the earthquake ground motion input energy and it will continue controlling the deformation of the primary structural system.

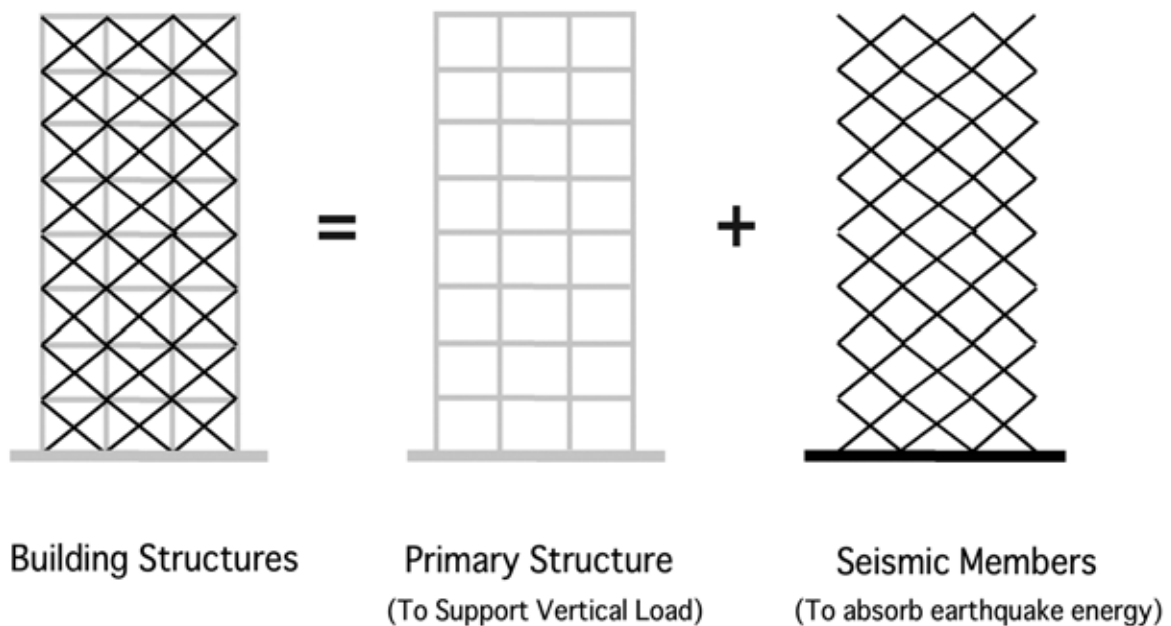

*Fig. 5 Concept of damage-controlled structures.*

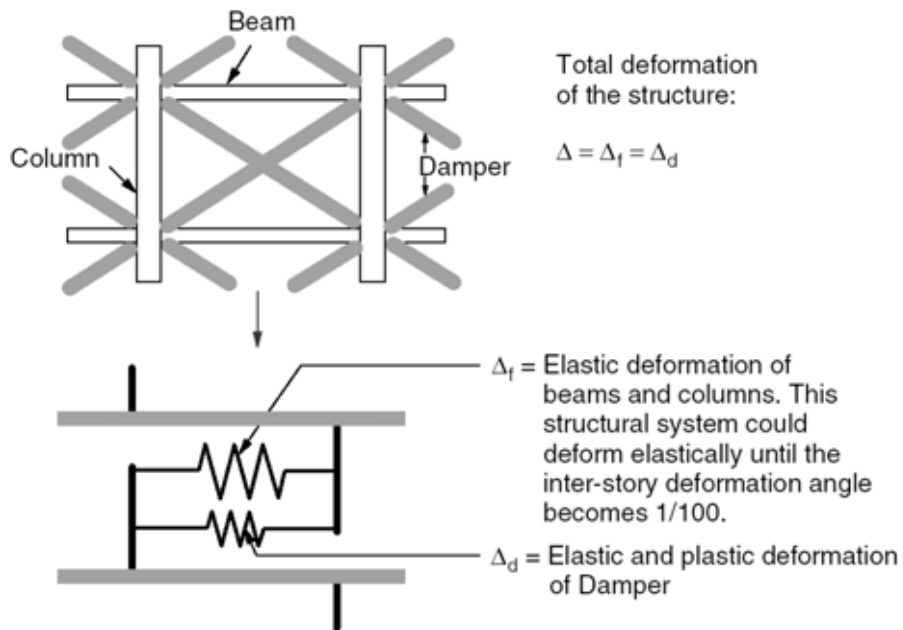

Fig. 6 Structure with dampers.

	Small/medium earthquake	Large earthquake
Conventional	<p>Frame</p> <p>Elastic</p>	<p>Frame</p> <p>Inelastic</p>
Damage Controlled	<p>Frame</p> <p>Elastic</p> <p>Damper</p> <p>Inelastic</p>	<p>Frame</p> <p>Elastic</p> <p>Damper</p> <p>Inelastic</p>

Fig. 7 Comparison between conventional and damage controlled structural models.

Under severe earthquake ground motions, the conventional moment resisting frame structure relies on its own yielding capacity to dissipate the input energy, and therefore, will sustain large plastic deformations, which means a large amount of damage. The larger the demanded plastic deformations (physical ductility) the larger will be the damage of the entire moment resisting frame system. On the other hand, if a damage controlled structures system is used, it will be possible to control the response of its primary structural system such that it remains elastic, because the energy dissipation component or system will increase the stiffness, strength and particularly the energy dissipation capacities of the entire structural system.

The advantage of the damage controlled structures is not only in protecting the primary structure from damage during a severe earthquake ground motion, but also in reducing the construction cost when compared with that of conventional moment resisting frame. According to the report of Nikkei Architecture, "steel buildings designed as damage controlled structures the total weight of the steel can be reduced by 20%" [19]. Furthermore, as it has been previously pointed out, perhaps a more important advantage of damage controlled structures is that after a severe earthquake ground motion if its energy dissipation components have been damaged, they can be quickly removed and replaced.

## 6. Applications in Tall Buildings in Japan

Since the Hyogoken-Nanbu earthquake, many building projects were designed based on the concept of damage controlled structures. Since 2000, approximately 80% of the high-rise buildings with heights more than 60 m were designed based on this concept of damage controlled structures.

### 6.1 Central Government Building

The Central Government Building (Figure 8) located in Chiyoda-ku, Tokyo, is a typical damage controlled structures combining hysteretic energy dissipation of steel shear walls and viscous fluid damper. This building was designed by the Architecture Department of the Ministry of Construction and Kume Sekkei Co., Ltd. The total height is 144.5 m, including a 55 m antenna tower on the roof. The superstructure above the ground level is a moment-resisting steel frame installed with various dampers, while the underground structure is a steel reinforced concrete frame with reinforced concrete shear walls. The columns and beams of the primary structure used SN490B steel (maximum strength is 490MPa). The primary structure is designed to behave elastically even under a severe earthquake ground motion whose maximum ground velocity is 50 cm/sec (corresponding to  $A_g$  of 500 cm/sec<sup>2</sup>). Most of the earthquake energy is absorbed and dissipated by the energy dissipating system. The hysteretic dampers (HDs) are steel walls made of extra-low yield point steel (yield point is 100MPa). The yield shear force level of HDs at the first floor location is assumed to be 5% of the total building weight. The distribution of yield shear force throughout the height of the building is assumed to be proportional to the distribution of yield shear force of the primary structure. On the other hand, the viscous dampers (VD) consist of two movable steel plates hung from the upper beam and three fixed steel plates stood on the bottom beam. The space between the movable steel plates and the fixed steel plates is filled with viscous liquid like silicone oil.

### 6.2 Art Hotel in Sapporo

The Art Hotel in Sapporo (Figure 9), designed and constructed by Kumagai Corporation, is another damage-controlled building. This building is 96 m high and has 26 stories above the ground. The primary structure is a moment-resisting steel frame that is designed to support only the vertical service load. Two thousands of slit steel dissipation (SSD) made of mild strength steel (SN490B) with a yielding strength of 325MPa were installed in the building. During an earthquake shaking the SSD are subjected to shear deformations through the top and bottom bolts and consequently each slender bar experiences bending deformation and starts yielding quickly at the end parts of the bar, even under small shear deformation, because the cross section of each bar is very small. Since the yielding parts of this kind of energy dissipation are easily concentrated on the small end parts of the



slender bars, the slits should be manufactured very carefully to avoid excessive local strain concentration. Because one piece of SSD is so light that someone could hold it in one hand, the biggest advantage is that the damaged SSD can be very easily replaced after a severe earthquake.



*Fig. 8 Central Government Building (courtesy of Kume Sekkei).*



*Fig. 9 Art Hotel in Sapporo (with HD). (Courtesy of Kumagai Corp.)*



*Fig. 10 DoCoMo Tokyo Building (with viscous damper) (courtesy of NTT facilities).*

### **6.3 DoCoMo Tokyo Building**

The building shown in Figure 10 is located in metropolitan Tokyo. The structural design was made by NTT Power and Building Facilities, Inc. This building has two parts. The lower 27 stories are mainly used for offices, and on the upper 23 stories is the antenna that is used for mobile communication. There are also three stories under ground. The total height of the building is 240 m. The structural system of the upper 23 stories (the antenna system) consists of a steel frame and steel brace structure. The structure of the lower 27 stories is steel frame with 76 viscous damping shear walls in both X and Y directions. The supplemental viscous damping wall system has the same energy dissipation capacity as that of a natural structural damping ratio of 5% in both directions. The viscous damping wall is a high-quality, highly stable damping system that has been used in more than 10 tall building projects since it was first used in a seismic building in 1988. Because of the use of an additional viscous damping wall, the primary steel structure is designed to remain elastic even under a level-2 strong earthquake ground motion with a maximum velocity of 50 cm/sec.

## **7. Conclusions**

The basic concept for such a design is to consider the integrated building as a combination of two different structural systems: the elastic primary structure that is designed primarily to resist elastically the vertical service loads, and the energy-dissipation structural system or component to resist the effects of lateral earthquake ground motions. The damage caused by the earthquake is controlled by the energy dissipation system. The primary structure remains elastic even during an extremely large earthquake ground motion. In this chapter, the concept and philosophy of the damage controlled structures were reviewed. Results obtained from some static cyclic loading tests of models of the main part of a steel special moment resisting frame and a damage-controlled steel frame were presented. The results clearly show the advantages of the damage-controlled structures

over the conventional moment resisting frame. Selected actual building projects designed on this concept were also discussed, as well as their advantages and disadvantages.

In Japan at the present time, the concept of damage-controlled structures is being applied only to high-rise buildings over 60 m in height. It has still not yet spread to lower-rise buildings (under 60 m). This is mainly because of a rule that the steel structure must be designed within the elastic region for the base shear coefficient of 0.2 associated with a moderate earthquake. Because this rule has been accepted for more than 50 years — since the end of the World War II — it is not simple to change it. As mentioned in this chapter, the brace and shear wall begins to yield when the interstory deformation angle is about 1/500. Since the primary structure can be kept in its elastic range until the interstory deformation reaches 1/200, it is reasonable to allow the braces or shear walls or both to yield. In Autumn 2005, the earthquake-resistant design method for buildings based on energy balance, which was proposed by Professor Hiroshi Akiyama [20], [21], will be included in the National Building Design Law of Japan. According to this building design law, the plastic deformation energy dissipation will be allowed for the seismic members even for a small and moderate earthquake level. Thus, 2005 will be the year when Japanese seismic design methodology drastically changes. At last, the application of the concept of damage controlled seismic design has already begun to spread to the substructure of bridges in both Japan and the United States. It is expected to be widely used by the seismic-sensitive countries worldwide [22].

## References

- [1] WADA A., CONNOR J.J., KAWAI H., IWATA M. and WATANABE A., "Damage tolerant structures", *Fifth US-Japan Workshop on the Improvement of Building Structural Design and Construction Practices*, pp. 1–12. (1992).
- [2] BERTERO V.V., "State-of-the-art report on the use of innovative strategies and techniques to reduce seismic risk", *Earthquake Engineering Research Center*, University of California, Berkeley. (1997).
- [3] HUANG Y.H., WADA A. and IWATA M., "Damage tolerant structures with hysteretic dampers", *Journal of Structural Engineering*, AIJ, 221–234. (1994).
- [4] SOONG T.T. and CONSTANTINOU M.C., *Passive and Active Structural Vibration Control in Civil Engineering*, Springer-Verlag, New York. (1994).
- [5] SOONG T.T. and DARGUSH G.F., *Passive Energy Dissipation Systems in Structural Engineering*, John Wiley & Sons, New York. (1997).
- [6] WADA A. and HUANG Y.H., "Preliminary seismic design of damage tolerant tall building structures", *Proceedings of Symposium on A New Direction in Seismic Design*, Tokyo, pp. 77–93. (1995).
- [7] WADA A., IWATA M. and HUANG Y.H., "Seismic design trend of tall steel buildings after the Kobe earthquake", *Passive Energy Dissipation and Control of Vibrations of Structures*, Taormina, Italy, pp. 251–269. (1997).
- [8] WADA A., HUANG Y.H. and NAKAMURA H., "Dynamic analysis of three dimensional elastic frames incorporating passive energy dissipation systems", *Proceedings of Second Japan-UK Workshop on Implications of Recent Earthquakes on Seismic Risk*, Tokyo Institute of Technology, Tokyo, pp. 317–328. (1998).
- [9] REINA P. and NORMILE D., "Fully braced for seismic survival, Cover story seismic design", *Engineering News Record*, July, 34–36. (1997).
- [10] BERTERO V.V., "Lessons learned from structures damaged in recent earthquakes", *Proceedings 7th World Conference on Earthquake Engineering*, Istanbul, Turkey, Vol. 4, pp. 257–264. (1980).
- [11] ENGELHARDT M.D. and SABOL T.A., "Lessons learned from the Northridge earthquake: Steel moment frame performance", *Proceedings of Symposium on a New Direction in Seismic Design*, Tokyo, pp. 1–14. (1995).
- [12] CARPER K.L., "Lessons learned from the 1994 Northridge earthquake: Performance of steel

moment frames", *Journal of Performance of Constructed Facilities*, 12(4), 171. (1998).

- [13] KRAWINKLER H., "Preliminary observations and thoughts on building damage in the January 17, 1994 Northridge earthquake", *Flash of the Investigation on the Disaster of Northridge Earthquake in 1994*, AIJ, Tokyo, pp. 73–82. (1994).
- [14] Steel Committee of Kinki Branch, *Investigation Report on the Damage of Steel Building Structures During 1995 Hyogo-ken Nanbu Earthquake*, AIJ (in Japanese), (1995).
- [15] OLIVETO G., *Innovative Approaches to Earthquake Engineering*, WIT Press, Southampton, U.K. (2002).
- [16] CONNOR J.J., WADA A., IWATA M. and HUANG Y.H., "Damage-controlled structures. I: Preliminary design methodology for seismically active regions", *Journal of Structural Engineering*, ASCE, 123(4), 423–431. (1997).
- [17] CONNOR J.J. and KLINK B.S.A., *Introduction to Motion Based Design*. Computational Mechanics Publications, Southampton, U.K., and Boston. (1996).
- [18] CONNOR J.J. and WADA A., "Performance based design methodology for structures", *International Workshop on Recent Development in Base-Isolation Techniques for Buildings*, Tokyo, pp. 57–70. (1992).
- [19] Nikkei Architecture, "Art Hotel Sapporo, two thousand hysteretic dampers reduce 20% steel weight", No. 588, pp. 202–205 (in Japanese). (1997).
- [20] AKIYAMA H., *Earthquake-Resistant Limit State Design for Buildings*, University of Tokyo Press, Tokyo. (1985).
- [21] AKIYAMA H., *Earthquake-Resistant Design Method for Buildings Based on Energy Balance*, Gihodo Press, Tokyo (in Japanese). (2002).
- [22] BOZORGNIA Y., BERTERO V.V., *Earthquake Engineering from Engineering Seismology to performance-based Engineering*, CRC Press. (2004).